

DIMENSION DETAILS AND RATINGS

ALL-WET SERIES AW-MP SPLIT

ALL-WET Split In-Line Pie Connector

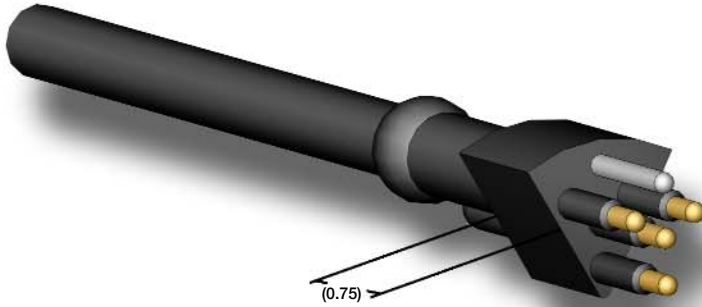

ALL-WET SERIES AW-S-BC

ALL-WET Split Bulkhead Connector

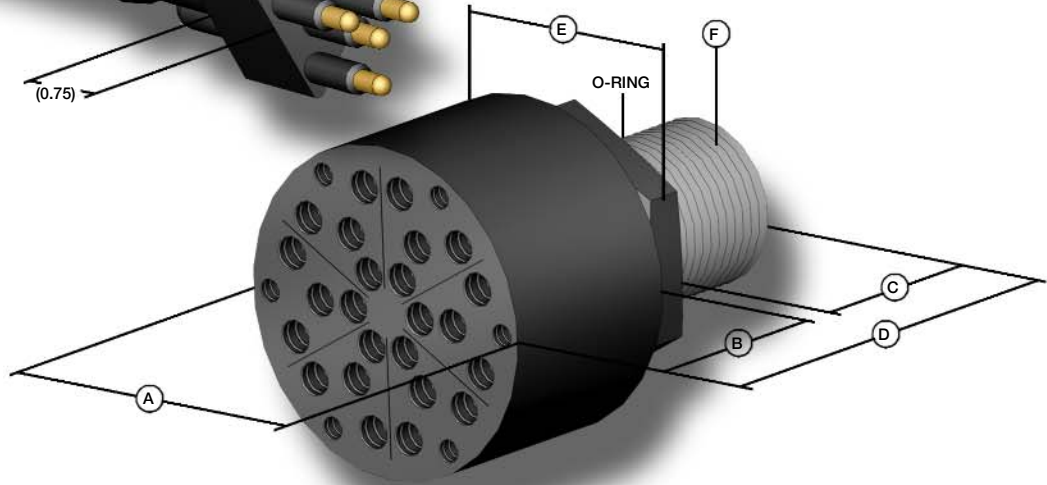

CONNECTOR	A - DIAMETER (INCHES)	B - (INCHES)	C - (INCHES)	D - (INCHES)	E - (INCHES)	F	O - RING	BC 18" TEFLON TYPE E HOOK-UP WIRE	MP w/18" CABLE	VDC	AMP PER CONTACT	CABLE AMPACITY	* BULKHEAD MOUNTING TORQUE (INCH POUNDS)
AWL-2/4	1.00	1.16	0.75	2.42	1.00	1/2-20 UNF-2A	2-114	18 AWG	18/2 SJO	300	19	7.0	50
AWM-2/12	1.25	1.16	0.75	2.42	1.25	1/2-20 UNF-2A	2-114	20 AWG	18/2 SJO	300	19	7.0	50
AWQ-2/8	2.00	1.28	1.00	2.80	1.50	1-14 UNS-2A	2-123	18 AWG	18/2 SO	600	19	7.0	125
AWQ-2/12	For dimension details and ratings please contact SEA CON®.												
AWQ-6/12	2.00	1.28	1.00	2.80	1.50	1-14 UNS-2A	2-123	18 AWG	18/6 SO	600	19	5.6	125
AWQ-2/16	2.00	1.28	1.00	2.80	1.50	1-14 UNS-2A	2-123	18 AWG	18/2 SO	600	19	7.0	125
AWQ-2/24	2.00	1.28	1.00	2.80	1.50	1-14 UNS-2A	2-123	18 AWG	18/2 SJO	300	10	7.0	125
AWQ-4/24	2.00	1.28	1.00	2.80	1.50	1-14 UNS-2A	2-123	18 AWG	18/4 SO	600	19	5.6	125
AWQ-4/28	2.00	1.28	1.00	2.80	1.50	1-14 UNS-2A	2-123	18 AWG	18/4 SO	600	19	5.6	125
AWQ-8/24	2.00	1.28	1.00	2.80	1.50	1-14 UNS-2A	2-123	18 AWG	18/8 SO	600	19	4.9	125
AWQ-8/32	2.00	1.28	1.00	2.80	1.50	1-14 UNS-2A	2-123	18 AWG	18/8 SO	600	10	4.9	125
AWQ-6/36	2.00	1.28	1.00	2.80	1.50	1-14 UNS-2A	2-123	20 AWG	18/6 SO	600	10	5.6	125
AWQ-12/36	2.00	1.28	1.00	2.80	1.50	1-14 UNS-2A	2-123	20 AWG	18/12 SO	600	10	3.5	125
AWQ-7/42	2.00	1.28	1.00	2.80	1.50	1-14 UNS-2A	2-123	20 AWG	18/7 SO	600	10	4.9	125
AWQ-1 & 2/54	For dimension details and ratings please contact SEA CON®.												
AWR-2/16	For dimension details and ratings please contact SEA CON®.												

NOTES:

- Pressure Rating: 10,000 psi, mated/1,000 psi, open face.
- Dummy Connector: Optional.
- Dummy Shorting Plug Connector: Optional.
- Connectors must be lubricated prior to mating.
- Locking Sleeves: Optional (see page 14).
- Nut and washer: Optional.
- For GRE bulkhead mounting torques please contact SEA CON®.*
- Torque values referenced in this literature assume installation into dry metal threads. For other applications, please contact SEA CON® for recommendations.
- Contact SEA CON® for custom cable molding needs.
- Bulkhead Locking Sleeve. Factory installation only for AWL/M-BC (see page 14)
- Connectors are designed for installation onto one atmosphere vessels. Contact SEA CON® for recommendations if using compensated vessels.
- AWL-2/4 is available in 2 different MP's. 1) Has guide pin along with pins 1 & 4; 2) Has no guide pin and pins 3 & 4.